



## A Better Idea in Water Heating - Fuel Efficiency and Design Flexibility

This highly efficient product combines 82% efficiency with a simple, trouble free design, resulting in unequalled water heater durability, lime scale free operation and fewer service calls - And that translates to customer satisfaction!

### Loch-Heat™ Ceramic Tile

Provides "space age" insulating technology and durability by eliminating the need for less efficient, bulky combustion chamber materials (refractory). Loch-Heat ceramic tile will not crack or spall and provides the benefit of an overall water heater weight reduction of 25% over other refractory materials.

### Copper-Fin Heat Exchanger

The heart of the Copper-Fin water heater is its copper finned-tube heat exchanger. With this unique gasketless design, we've combined the best of both worlds: cast iron headers for long-lasting durability, and a copper finned-tube heat exchanger for high efficiencies and fast heat transfer. The gasketless heat exchanger design reduces the risk of leaks or system failures that are common with conventional water heaters. Plus, the unit's low-mass design means that water gets heated quickly. Not only is heat up time nearly instantaneous with these water heaters, the energy consumption and operating costs are lower too.

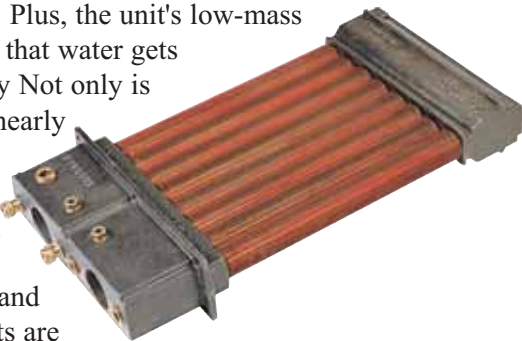

### Built-In Draft Hood

The lower overall height of the draft hood makes it easier to install the Copper-Fin water heater in all applications, especially in those instances where overhead space is limited.

## Copper-Fin® Gas Fired Water Heaters



### A Better Idea

The "Better Idea" system combines the Copper-Fin water heater with a separate round jacketed storage tank and manifold piping to provide a high performance water heating system. By separating the water heater and storage tank, standby losses are virtually eliminated and performance efficiency is further enhanced.

### Serviceability

This water heater is as flexible and convenient to install and service as it is efficient and compact. The heavy-duty stainless steel burners can easily be adapted for use with either natural or liquefied petroleum (LP) gas, and the water heater's design allows for easy access to all major components for servicing. The heat exchanger is designed to slide out the front of the water heater for faster maintenance, and Lochinvar backs it up with an exclusive 3-year Limited Warranty. For more information, call your Lochinvar dealer today.

# Copper-Fin® Water Heater Dimensions & Specifications

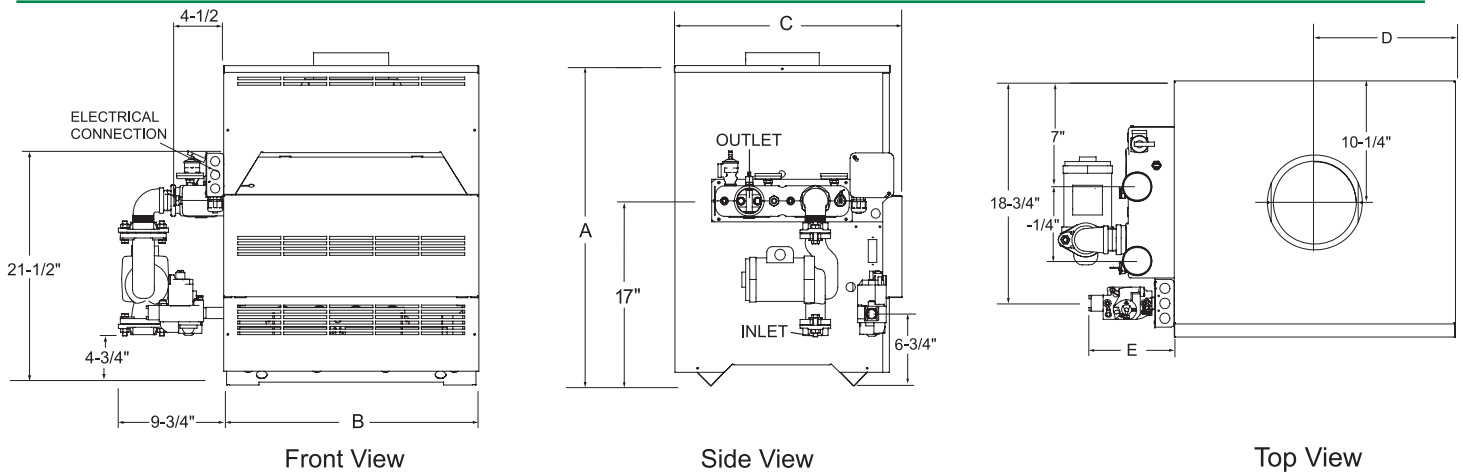

Model Number	Btu/Hr Input	GPH @ 100°F Rise	A	B	C	D	E	Vent Size	Gas Conn.	Shipping Weight
CWN090PM	90,000	89	29-1/2"	15-1/2"	21-1/2"	7-3/4"	6-1/4"	5"	1/2"	175
CWN135PM	135,000	134	29-1/2"	19-1/2"	21-1/2"	9-3/4"	6-1/4"	6"	1/2"	195
CWN180PM	180,000	179	29-1/2"	23-1/2"	21-1/2"	11-3/4"	7-1/4"	7"	3/4"	220
CWN199PM	199,999	198	29-1/2"	26-1/2"	21-1/2"	13-1/4"	7-1/4"	7"	3/4"	230
CWN225PM	225,000	224	29-1/2"	26-1/2"	21-1/2"	13-1/4"	7-1/4"	7"	3/4"	235
CWN270PM	270,000	268	29-1/2"	29 1/2"	21 1/2"	14 3/4"	7-1/4"	8"	3/4"	240
CWN315PM	315,000	313	29-1/2"	32-1/2"	21-1/2"	16-1/4"	6-1/4"	8"	3/4"	250
CWN360PM	360,000	358	29-1/2"	35-1/2"	21-1/2"	17-3/4"	8-1/4"	9"	1"	270
CWN399PM	399,999	397	29-1/2"	44-1/2"	22"	22-1/4"	5-1/2"	10"	1"	340
CWN500PM	500,000	497	34-1/2"	52-1/2"	22"	26-1/4"	9-1/2"	10"	1"	365

Notes: Change 'N' to 'L' to denote L.P. gas models  
 Inlet water connections are 1-1/2" NPT and outlet water connections are 2" NPT on 6-1/4" centers  
 Approved for indoor installation only  
 Performance data based on manufacturer test results

Electrical Requirements: 120 VAC / 2.5 AMP

## Standard Features

- 82% Thermal Efficiency
- Built-In Draft Diverter
- Stainless Steel Burners
- ASME Copper Finned Tube Heat Exchanger
- 160 psi Working Pressure
- Gasketless Heat Exchanger Design
- All Bronze Circulating Pump
- Pump Delay/Freeze Protection
- Remote Tank Thermostat
- Glass-Lined Water Surfaces
- Loch-Heat Ceramic Tile Combustion Chamber
- ASME Temperature & Pressure Relief Valve
- Manual Reset High Limit

- Terminal Strip
- Self Diagnostic Indicator Lights
- Automatic Reset High Limit
- 24 Volt Control System
- CSA Design Certified for Alcove Installation
- CSA Design Certified for Installation on Combustible Floors
- 3 Year Limited Warranty on Heat Exchanger

## Optional Equipment

- Adjustable High Limit w/ Manual Reset
- Contacts on any Failure (CW 315-500)
- Contacts for Air Louvers (CW 315-500)
- Cupro-Nickel Heat Exchanger
- Flow Switch
- Low Water Cut-Off
- Multi-Stack Frame
- PVC Venting Kit (CW 90-135)

## Firing Controls

- F1 - Standing Pilot (Standard CW 90-270)
- F9 - Intermittent Spark Ignition (Standard CW 315-500)
- F13 - GE GAP/FM/IRI
- F7 - California Code (CW 225-500)

FOR EASE IN ORDERING  
 BY MODEL NUMBER



This model is a 315,000 Btu/hr, natural gas Copper-Fin water heater.



**Lochinvar®**  
 High Efficiency Water Heaters, Boilers and Pool Heaters



Lochinvar Corporation • 300 Maddox Simpson Pkwy • Lebanon, TN 37090 • 615-889-8900 / Fax: 615-547-1000

[www.Lochinvar.com](http://www.Lochinvar.com)